

CORRAPOL[®]

Clear **Corrugated Sheet Ranges**
Technical Guide

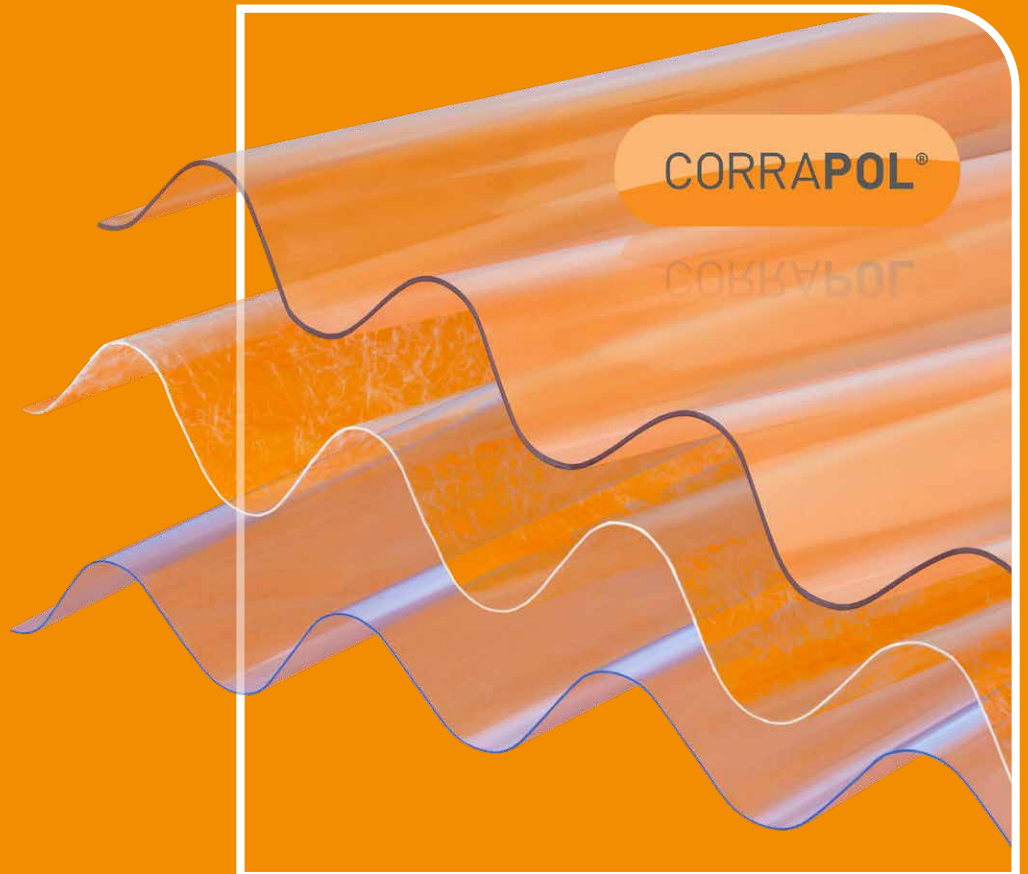

Clear Corrugated Sheet Ranges

The Corrapol® Clear Corrugated sheet range is manufactured for a wide variety of applications and offers different extrusions for varying longevity and budget requirements. The Corrapol® Stormproof provides a long lasting superior corrugated roof glazing solution, whereas the Corrapol® DIY grade provides a more cost effective option. This brochure provides a guide as to the range and specific benefits of each extrusion type which we manufacture, along with some technical data, and installation guidelines.



Common uses:

- ✓ Carports
- ✓ Greenhouses
- ✓ Canopies
- ✓ Shelters
- ✓ Verandahs
- ✓ Covered Walkways
- ✓ Swimming Pools
- ✓ Factory Partitions
- ✓ Cold Frames

Qualities:

- ✓ Suits a range of budgets
- ✓ World Class Flashings and Accessories
- ✓ Installer Friendly
- ✓ Universal Corrapol® Profile

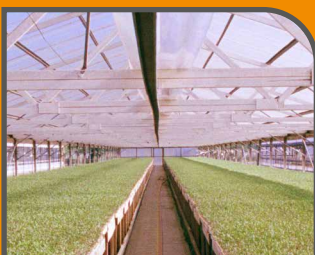

Corrapol® : Full Roof Structure

Below is a typical apex roof scenario showing how the Corrapol® system components are installed together for perfect results. The same methods and components can be used in most applications from Carports, Decking covers, BBQ shelters and other constructions.

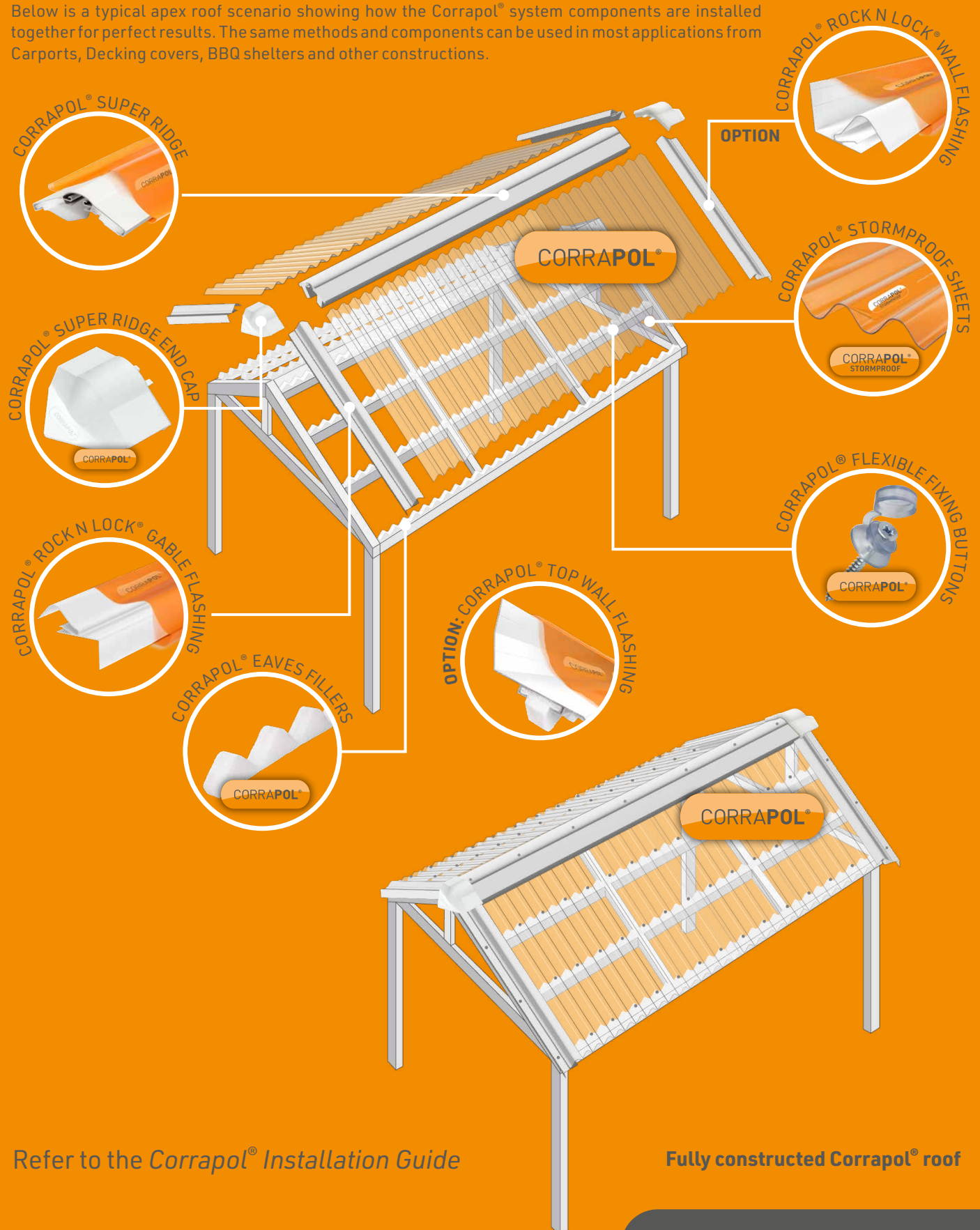

Refer to the *Corrapol® Installation Guide*

Fully constructed Corrapol® roof

Corrapol® Stormproof® : Low and High Profiles

Corrapol® Stormproof® sheets are the strongest and longest lasting sheet within the Corrapol® range. Extruded from virtually unbreakable plastic resin Corrapol® Stormproof® clear sheets offer superior strength, excellent clarity and above all unrivalled weathering characteristics resulting in a very long lifespan. This superior strength and longevity means that Corrapol® Stormproof® clear sheets will not go yellow or brittle with age, and won't crack during installation like lower cost PVC options tend to. Corrapol® Stormproof® clear sheets are made from resin which makes them 200 times stronger than glass of the same thickness which is generally considered to be virtually unbreakable and what we call 'Stormproof®'. The UV protection layer incorporated into the manufacturing process of Corrapol® Stormproof® sheets ensures they provide superior light transmission for many years to come.

Key Benefits:

- ✓ Maintains Great Light Transmission
- ✓ UV Protected
- ✓ High Impact Strength
- ✓ Virtually Unbreakable
- ✓ Estimated 25 year Lifespan
- ✓ Doesn't discolours like cheaper alternatives
- ✓ Doesn't Crack when Fixing like PVC

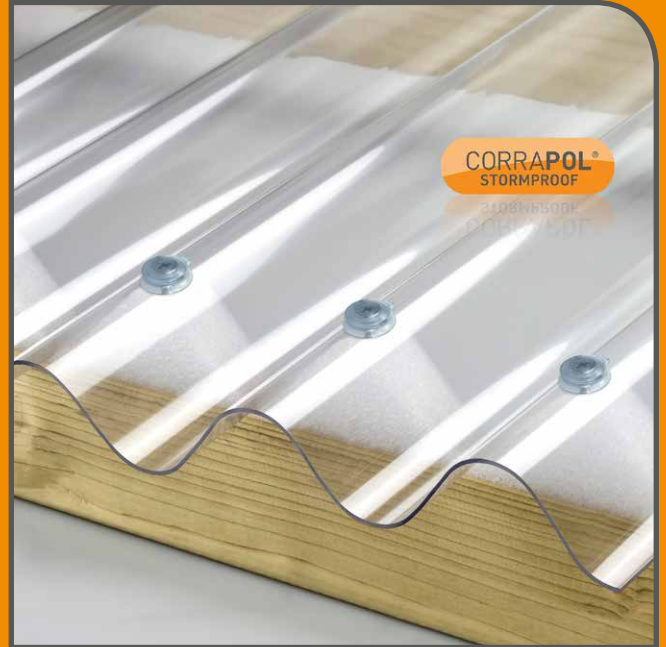

Corrapol® Stormproof® high profile in-situ view

Corrapol® Stormproof® : High Profile Sheets

Most Popular: Compatible with Rock N Lock® & Super Ridge

Common Uses:

- ✓ Carports
- ✓ Canopies
- ✓ Cold Frames
- ✓ Porches
- ✓ Greenhouses
- ✓ Agricultural Buildings/Barns
- ✓ Garages
- ✓ Covered Equestrian Areas

Corrapol®: High Profile Stormproof®	Code
Corrapol® Stormproof® High Profile Sheet - 950 x 1000mm	AC801
Corrapol® Stormproof® High Profile Sheet - 950 x 2000mm	AC802
Corrapol® Stormproof® High Profile Sheet - 950 x 2500mm	AC804
Corrapol® Stormproof® High Profile Sheet - 950 x 3000mm	AC806
Corrapol® Stormproof® High Profile Sheet - 950 x 4000mm	AC808

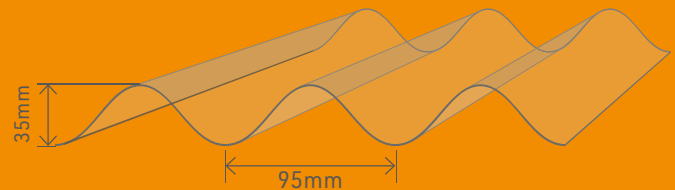

Corrapol® Stormproof® : Low Profile Sheets

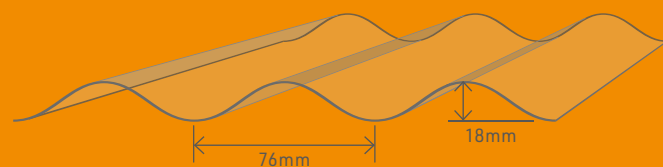

Corrapol®: Low Profile Stormproof®	Code
Corrapol® Stormproof® Low Profile Sheet - 840 X 1830mm	AC19
Corrapol® Stormproof® Low Profile Sheet - 840 X 2440mm	AC20
Corrapol® Stormproof® Low Profile Sheet - 840 X 3050mm	AC21
Corrapol® Stormproof® Low Profile Sheet - 840 X 3660mm	AC22

Corrapol®-PVC : DIY Grade Sheets

Whilst not as strong or as long lasting as the Corrapol® Stormproof range, Corrapol®-PVC DIY Grade Sheets offer a lower cost and are ideal for areas where impact resistance is not important and also where direct sunlight is limited. In areas like this, the Corrapol®-PVC DIY Grade range provides an excellent solution and will provide an excellent waterproof solution with good light transmission.

Key Benefits:

- ✓ Low Cost
- ✓ Maintains Great Light Transmission
- ✓ Allows a Degree of Visibility Whilst Retaining Privacy
- ✓ Lightweight
- ✓ Ideal for DIY

Common Uses:

- ✓ DIY Projects
- ✓ Lean-tos

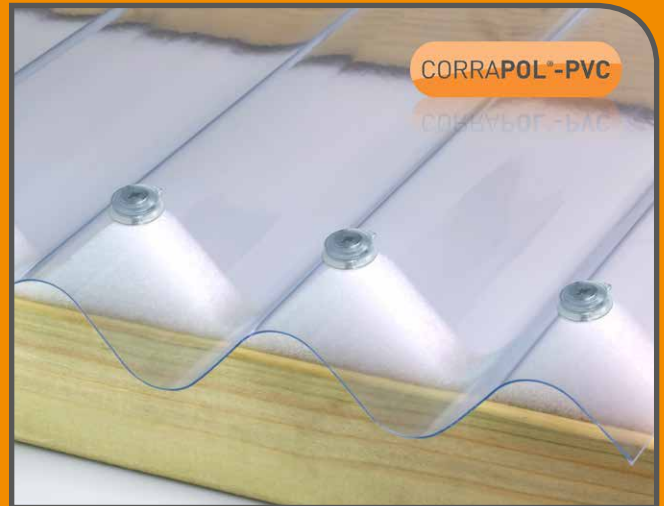
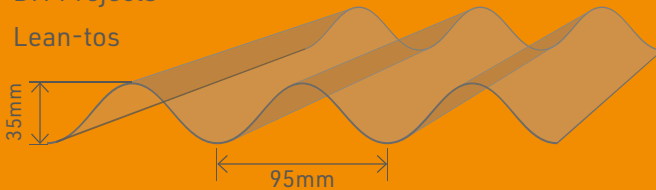

Corrapol®-PVC: DIY Grade Sheet	Code
Corrapol®-PVC DIY Grade Sheet - 950 X 1000mm	AC700
Corrapol®-PVC DIY Grade Sheet - 950 X 2000mm	AC702
Corrapol®-PVC DIY Grade Sheet - 950 X 2500mm	AC704
Corrapol®-PVC DIY Grade Sheet - 950 X 3000mm	AC706

Corrapol®-GRP : Polyester Translucent Sheets

This type of Corrapol® provides excellent strength, similar to that of the Corrapol® Stormproof range, however the light transmission is lower due to the fibres in the resin mix. Where areas where direct sunlight is relatively low, the Corrapol®-GRP Translucent Sheets are an excellent solution with high impact strength and excellent rigidity.

Key Benefits:

- ✓ Provides Privacy
- ✓ Maintains Great Light Transmission
- ✓ Allows a Degree of Visibility Whilst Retaining Privacy
- ✓ High Strength
- ✓ High Rigidity

Common Uses:

- ✓ Agricultural Buildings/Barns
- ✓ Garages

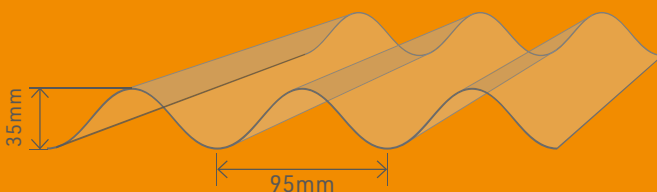

Corrapol®-GRP : Polyester Sheet	Code
Corrapol®-GRP Polyester Sheet - 950 X 2000mm	AC602

Corrapol® : Rock N Lock® Gable Flashing

The Corrapol® Rock N Lock® Gable Flashing is a world first that we have manufactured to help our Distributors' Customers easily finish one of the most challenging area of any roof project; the gable. The Patent Pending and Registered Design allows users to quickly and easily create a robust, long-lasting Gable flashing to the gable end of any Corrapol® roof, with a simple Rock N Lock® system.



Mill



White

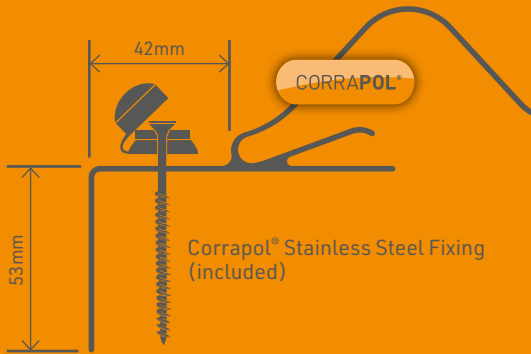

Corrapol® : Rock N Lock® Gable Flashing	Code
Corrapol® Rock N Lock® Gable Flashing - Mill - 2m	AC220M
Corrapol® Rock N Lock® Gable Flashing - Mill - 3m	AC222M
Corrapol® Rock N Lock® Gable Flashing - Mill - 6m	AC228M
Corrapol® Rock N Lock® Gable Flashing - White - 2m	AC220WH
Corrapol® Rock N Lock® Gable Flashing - White - 3m	AC222WH
Corrapol® Rock N Lock® Gable Flashing - White - 6m	AC228WH

a

Corrapol® Rock N Lock® Gable Flashing



b

Tilt the **Corrapol® Rock N Lock® Gable Flashing** to the side and fit the first corrugated sheet peak into the flashing.

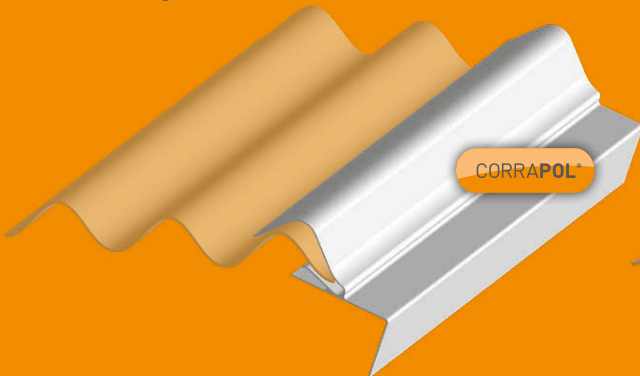

c

Straighten the **Corrapol® Rock N Lock® Gable Flashing** into place giving a waterproof and visually pleasing finish to the edge of your roof structure.



Corrapol® : Rock N Lock® Wall Flashing

The all new Corrapol® Rock N Lock® Wall Flashing is another world first that we have manufactured to help installers complete a roofs gable when abutting up to a wall. Allowing users to quickly and easily create a robust, long-lasting wall flashing the Patent Pending and Registered Design makes it simple to fix and seal the wall end of any Corrapol® roof. With the signature Rock N Lock® fixing system the Corrapol® Rock N Lock® Wall Flashing locks into place to create an extra level of waterproofing.



Mill



White

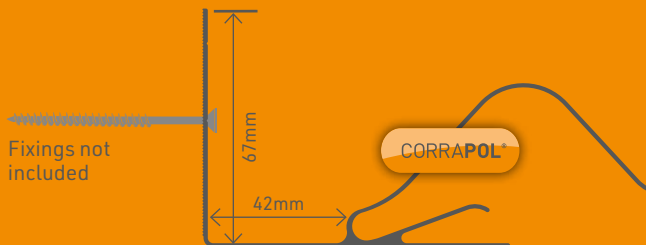

a
Corrapol® Rock N Lock®
Wall Flashing

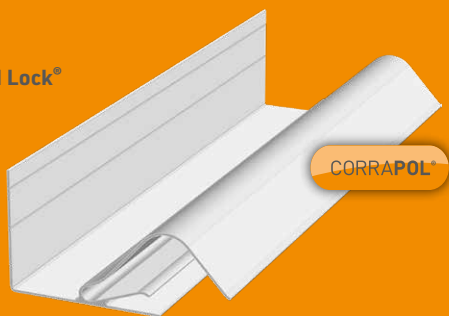

b
Tilt the **Corrapol® Rock N Lock® Wall Flashing** to the side and fit the first corrugated sheet peak into the flashing.

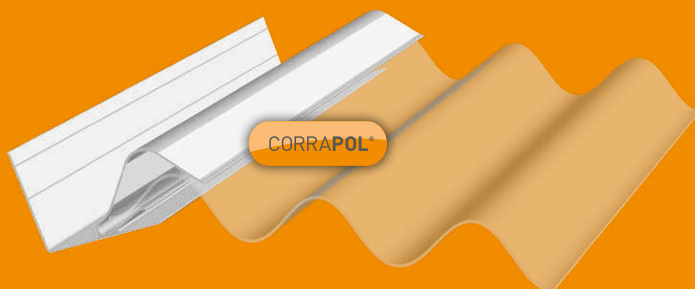

c
Lock the **Corrapol® Rock N Lock® Wall Flashing** into place giving a waterproof and visually pleasing finish to the wall edge of your roof structure.

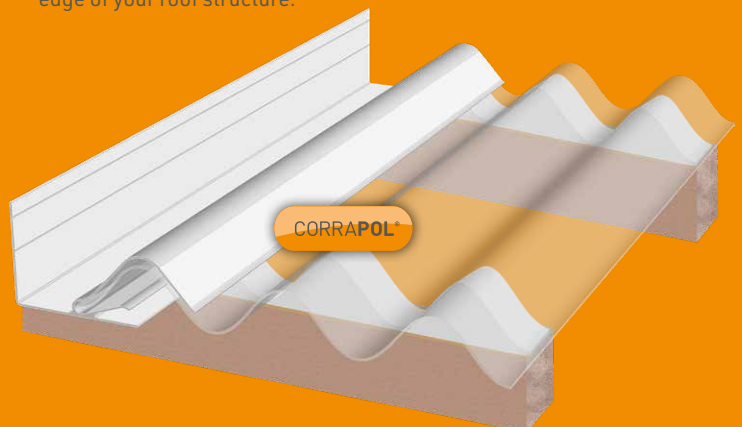

Corrapol® : Rock N Lock® Wall Flashing	Code
Corrapol® Rock N Lock® Wall Flashing - Mill - 2m	AC420M
Corrapol® Rock N Lock® Wall Flashing - Mill - 3m	AC422M
Corrapol® Rock N Lock® Wall Flashing - Mill - 6m	AC428M
Corrapol® Rock N Lock® Wall Flashing - White - 2m	AC420WH
Corrapol® Rock N Lock® Wall Flashing - White - 3m	AC422WH
Corrapol® Rock N Lock® Wall Flashing - White - 6m	AC428WH

Corrapol® : Aluminium Super Ridge

Manufactured in White and Mill finish the Corrapol® aluminium Super Ridge is another game changer in the corrugated market. Protecting the ridge of a roof is crucial and with the installation of the Corrapol® Super Ridge you can add years of lifespan to your roof. Designed with integrated pre-formed foam gaskets to fit the corrugations of the Corrapol® sheets, the Corrapol® Super Ridge is an installer's dream. The patented design allows for a good variety of roof pitches with the gaskets being flexible enough to seal again the Corrapol® sheets, and create a longer lasting superior ridge solution.



Mill



White

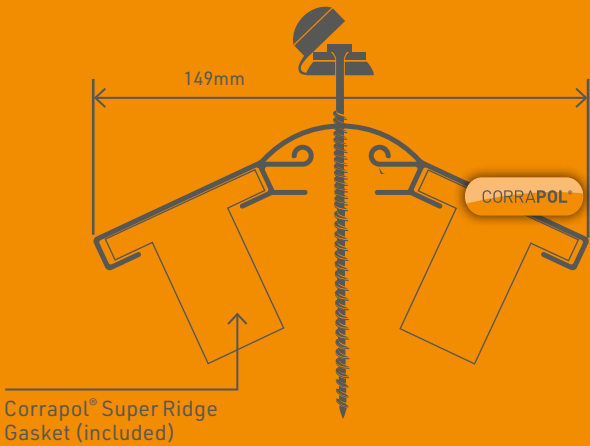

Corrapol® : Aluminium Super Ridge	Code
Corrapol® Aluminium Super Ridge Set - Mill - 2m	AC330M
Corrapol® Aluminium Super Ridge Set - Mill - 3m	AC332M
Corrapol® Aluminium Super Ridge Set - Mill - 6m	AC338M
Corrapol® Aluminium Super Ridge Set - White - 2m	AC330WH
Corrapol® Aluminium Super Ridge Set - White - 3m	AC332WH
Corrapol® Aluminium Super Ridge Set - White - 6m	AC338WH

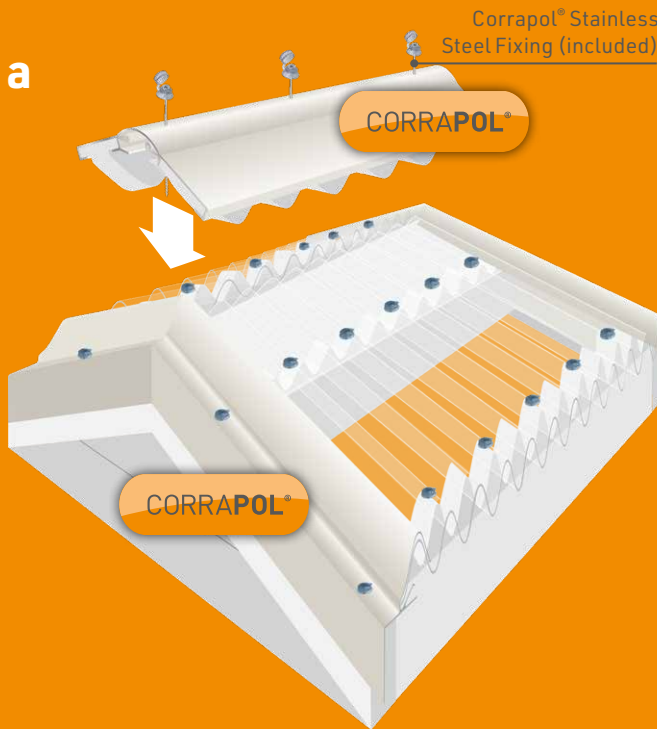

Corrapol® : Aluminium Super Ridge End Cap

Crafted with striking form, our all new Corrapol® Super Ridge End Cap is designed to be the crowning element to every Corrapol® Corrugated ridged roof. Shaped to add new level of waterproofing to the end of a Corrapol® Super Ridge, the new Super Ridge End Cap helps protect one of the most crucial areas of installation and provides an unrivalled finish to user's roofs. Manufactured from aluminium, the new Corrapol® Super ridge is very durable and adds extra longevity to the lifespan a roof. The simple and innovative location prongs ensure that installation is fast and easy for DIYers and installers alike.



Mill



White



Corrapol® Super Ridge End Caps fit into the lower slot of both sides of the Corrapol® Super Ridge bar.

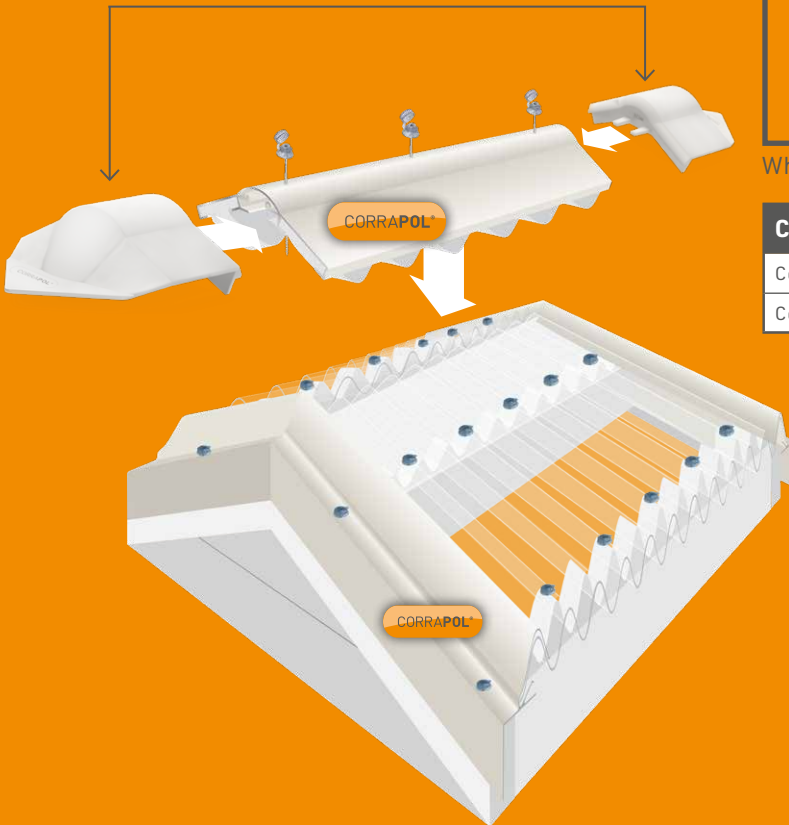

Corrapol®: Aluminium Super Ridge End Cap	Code
Corrapol® Super Ridge Endcap - Mill	AC340M
Corrapol® Super Ridge Endcap - White	AC340WH

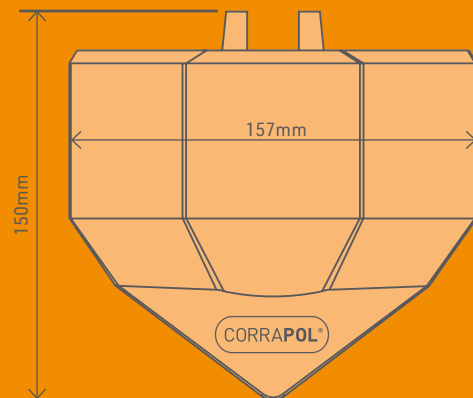

Plan View

Corrapol® Super Ridge End Cap fits into the lower slot of the Corrapol® Super Ridge.

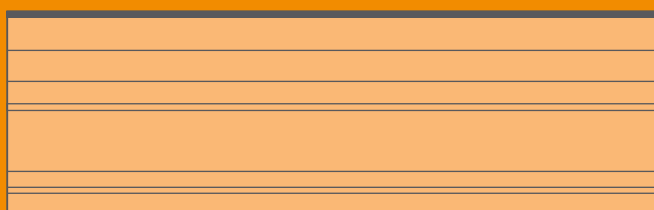

Cross Section of Corrapol® Super Ridge

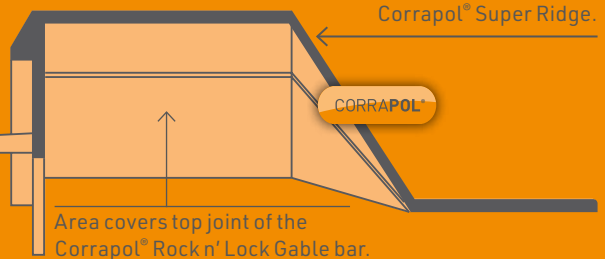

Cross Section of Corrapol® Super Ridge End Cap

Corrapol® : Aluminium Top Wall Flashing

Our new Corrapol® Top Wall Flashing is another innovation designed with ease of installation and quality finish in mind. With its unique bi-angled shape the Top Wall Flashing works with multiple roof pitches making it easy for any installer to add to their roof. The unique patented and/or Registered Design foam gaskets help create a firm seal on the Corrapol® sheets below, whilst working with any pitch, ensuring strong waterproofing across the top of the roof. As with our other innovative aluminium components, the Corrapol® Top Wall Flashing is manufactured to match the colours of the Corrapol®-BT sheets in vibrant Red, Green, Black and Brown!



This illustration of the Corrapol® Top Wall Flashing indicates how the flat angle verticle edge is fixed directly onto the wall and made waterproof by covering the angled side and fixings with lead flashing.



Mill



CORRAPOL®



White



CORRAPOL®

Corrapol®: Wall Top Flashing	Code
Corrapol® Wall Top Flashing - Mill - 2m	AC620M
Corrapol® Wall Top Flashing - Mill - 3m	AC622M
Corrapol® Wall Top Flashing - Mill - 6m	AC628M
Corrapol® Wall Top Flashing - White - 2m	AC620WH
Corrapol® Wall Top Flashing - White - 3m	AC622WH
Corrapol® Wall Top Flashing - White - 6m	AC628WH

Corrapol® : Pent Roof Flashing

Our Corrapol® Pent Flashing is designed to create a watertight and robust seal on the upper edge of a corrugated pent roof.

Produced from quality aluminium, the pent roof flashing has been created to provide a long-lasting roof flashing solution. It is compatible with all our high profile Corrapol® clear corrugated sheets, including the Stormproof®, GRP and PVC ranges.

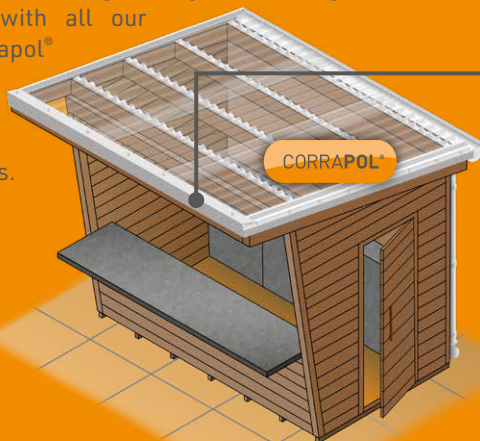

White



Mill



Corrapol®: Pent Roof Flashing	Code
Corrapol® Pent Roof Flashing - Mill - 2m	AC640M
Corrapol® Pent Roof Flashing - Mill - 3m	AC642M
Corrapol® Pent Roof Flashing - Mill - 6m	AC648M
Corrapol® Pent Roof Flashing - White - 2m	AC640WH
Corrapol® Pent Roof Flashing - White - 3m	AC642WH
Corrapol® Pent Roof Flashing - White - 6m	AC648WH

Corrapol® : Eaves Filler

Corrapol® Foam Eaves Filler is manufactured from a flexible foam allowing successful sealing and draught proofing. The Corrapol® Foam Eaves Filler is made with closed-cell foam so does not absorb moisture and can also be used to further improve waterproof sealing.

Corrapol® : High Profile Eaves Filler	Code
Corrugated High Profile Foam Eaves Filler	AC42



High-Profile Eaves Filler

Corrapol® : Low Profile Eaves Filler	Code
Corrugated Low Profile Foam Eaves Filler	AC40



Low-Profile Eaves Filler

Corrapol® : Superior Flexible Fixings

The Superior Corrapol® flexible fixings provide enhanced sealing to the contours of the curved peaks of the Corrapol® Stormproof sheets. Being a screw fixing they also enable the installer to control the fixing pressure, and allow removal of the fixings if needed. The caps are clear to give an aesthetically pleasing finish to the roof and can be used with either the white or mill finished Corrapol® Rock n' Lock Gable Flashing and Corrapol® Aluminium Super Ridge.

Corrapol® : Superior Flexible Fixing	Code
Corrapol® Clear Flexible Fixings	AC32



Clear Corrapol® Fixing Button

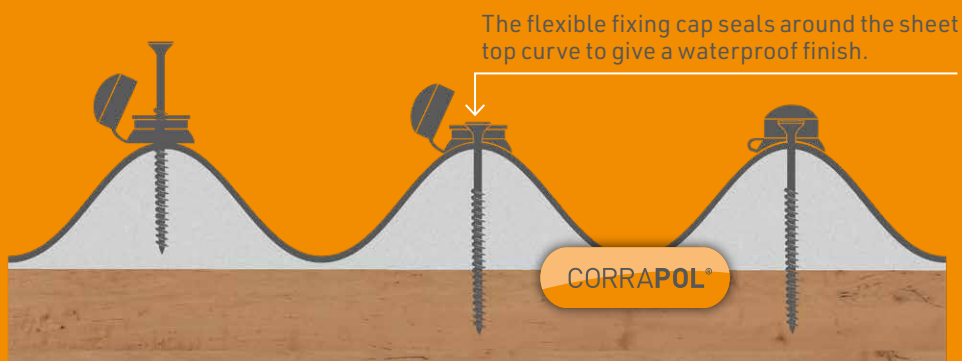

Corrapol® : Range Selector Guide

This Corrapol® Range Selection Guide provides a quick guide on the various properties of the different Corrapol® and Corrapol®-BT ranges, allowing you to quickly assess the best product for your project.

	CORRAPOL® STORMPROOF	CORRAPOL®-PVC	CORRAPOL®-GRP
LONG LIFE SPAN	✓✓✓✓	✓	✓
IMPACT RESISTANT	✓✓✓	✓	✓✓
UV PROTECTED	✓✓✓✓	✓	✓
HIGH STRENGTH	✓✓✓	✓	✓
LIGHT TRANSMISSION	✓✓✓✓	✓✓	✓
LIGHTWEIGHT / EASY-TO-CUT	✓✓✓	✓	✓
LOW COST	✓	✓✓✓	✓✓
RIGID	✓✓	✓	✓✓✓
PROVIDES PRIVACY	✓	✓	✓✓

Looking for Solid Colour Corrugated Sheeting?

➔ Check out our **Corramet®** or **Corrapol®-BT** Ranges.



Corrapol® Stormproof : Technical Data

The value and quality of a construction material is indicated by the standards which it meets. The tables below list the stringent international standards Corrapol® Stormproof is expected to meet, including excellent fire-resistant qualities. The Corrapol® Stormproof resin has a softening point in excess of 120°C. Most products extruded in polycarbonate and tested to BS476 Pt7 achieve a class 1(Y) rating. The international results depicted in the chart below show just how high a rating Corrapol® Stormproof has achieved worldwide. Corrapol® Stormproof is less flammable and has a higher melting point than fibreglass, acrylic or PVC sheets.

Flammability and Construction Standards

Standard	Country	Corrapol® Thickness	Method	Designation or Rating
Flammability	France	0.8-1.0mm	NFP 92501 NFP 92504 NFP 92505	M-1
Flammability	Germany	0.8-1.0mm	DIN 4102	B-1
Flammability	Israel	0.8mm	I.S. 755	V 2 2
Flammability	Dade County FL-USA	0.8mm	ASTM D-1929	Meeting the South-Florida Building Code 806°F
			D-1929	1004°F
			D-635	45 Sec
			D-635	1.77 in
			E-84	6
			E-84	78
			D-638	(weathering)
Flammability	USA	0.8mm	UL: UL723	4.7 47.0
			ASTM D-1929	490°C @ 4:3min 530°C @ 2:15min
			ASTM D-635	3.0 cm/min 30(Burning rate)
Flammability	USA Los Angeles	0.8mm	Los Angeles Building Code	CC2 (Section 2603)
Hurricane Code	Dade County Florida, USA		AS2376-1980	Passed
Wind Load	Australia			Complies
Cyclonic Wind Load	Australia		AS 2424	Passed
Sandbag Impact testing	Australia		AS2424, AS 1562-3	Passed
TNO Hail Test	Netherlands		1999-CON-LBC/ B7139/ JNE	Passed
TNO Load Test (Pressure)	Netherlands		1999-CON-LBC/ B7157/ JNE	Passed

Typical Properties

W	Property	Conditions	ASTM Method	Units-SI	Value
Physical	Density		D-1505	g/CM ³	1.2
	Water absorption	24hr.@23°C	D-570	%	0.15
Mechanical	Tensile strength at yield	10mm/min	D-638	MPa	62
	Tensile strength at break	10mm/min	D-638	MPa	65
	Elongation at yield	10mm/min	D-638	%	7
	Elongation at break	10mm/min	D-638	%	>80
	Tensile modulus of elasticity	10mm/min	D-638	MPa	2,300
	Flexural modulus	1.3mm/min	D-790	MPa	1,890
	Flexural strength at yield	1.3mm/min	D-790	MPa	93
	Notch impact strength izod	23°C	D-256	J/m	800
	Notch impact strength	23°C	D-256	J/m	800
	Impact falling weight		ISO-663/1 ^a	J	50
Rockwell hardness		D-785	R scale	118	
Thermal	Long term service temperature			°C	-50 to +100
	Short term service temperature			°C	-50 to +120
	Heat deflection temperature	Load: 1.82 MPa	D-648	°C	135
	Vicat softening temperature	Load: 1kg	D-1525	°C	150
	Co-efficient of linear thermal expansion		D-696	10 ⁻⁵ cm/cm°C	6.5
	Thermal conductivity		C-177	W/m K	0.21
	Specific heat capacity		C-351	kJ/kg K	1.3
Optical	Haze		D-1003	%	<0.5
	Light transmission		D-1003	%	90
	Refractive index		D-542		1.57
	Yellowness index		D-1925		<1
Electrical	Dielectric constant	1kHz	D-150		2.6
		1MHz	D-150		2.4
	Dissipation factor	1kHz	D-150		0.005
		1MHz	D-150		0.02
	Dielectric strength short time	500 V/s	D-149	kV/mm	20
	Surface resistance	Ketley	D-257	0hm	4.1x10 ¹⁵
Volume resistance	Ketley	D-257	0hm-cm	1.7x10 ¹⁷	

Corrapol® Stormproof : Light Transmission

Corrapol® Stormproof almost totally blocks harmful UV radiation whilst still allowing exceptional levels of visible light transmission. The graph below shows comparisons with other products.

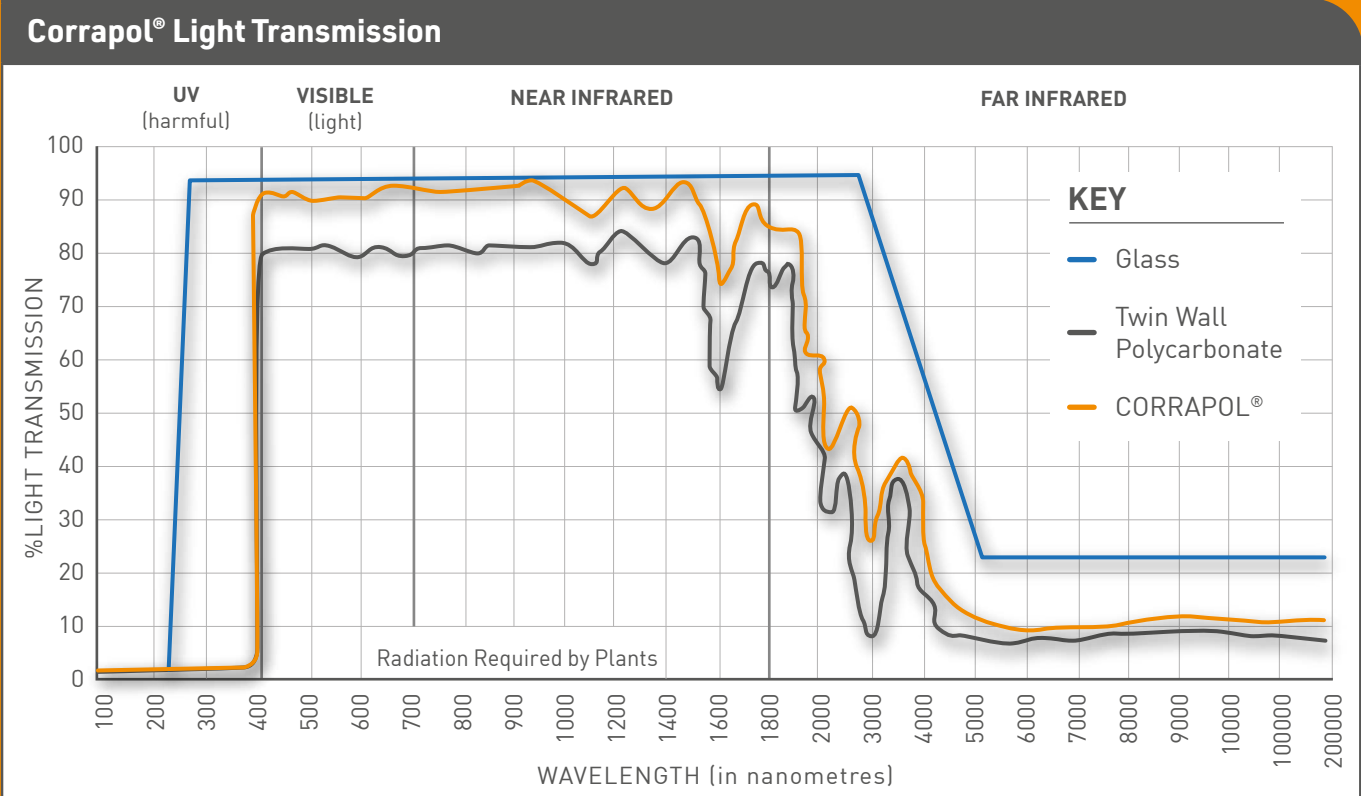

Other Ranges We Manufacture

Please get in touch for more information about the many other products we manufacture.



WARNING : REGISTERED DESIGNS & PATENTS

The IP of the designs in this brochure are protected by internationally registered design rights. Many products are also protected with active or pending Patents. Clear Amber will not hesitate to take appropriate legal action if its rights in this respect are infringed.

© Copyright – Clear Amber Group Ltd - November 2024. No part of this publication may be copied, reproduced, scanned, or stored in any electronic database, whether in whole or in part, in any form or by any means, without permission in writing from Clear Amber. Clear Amber will not hesitate to take appropriate legal action if its rights in this respect are infringed.

Inasmuch as Clear Amber have no control over the circumstances in which our material may be used, or site specific parameters, we cannot guarantee that any particular results will be achieved. Users should carry out their own tests to determine the suitability of the material for their application.